

M1716 Console

17" LCD monitor
Keyboard with touch pad
16-port Matrix DB-15 KVM



» Features

- 1U module design, 25.6" depth
- 17" LCD display with OSD menu
- 104-key keyboard with mouse, PS/2 or USB connectors
- Available with touchpad or trackball mouse (opt)
- 16 port Matrix DB-15 KVM switch
- 2 user console, optional for 3/4 user console
- 110/220VAC power supply

» Specifications

Material:

Heavy-duty steel

LCD Panel:

Size: 17"
Max. Resolution: 1280 x 1024
Brightness (cd/m²): 300nit
Contrast Ratio: 1000:1
Response time: Times 1.3ms
Display Area: 338 x 270mm
Viewing Angle: 160° Horizontal, 160°Vertical
Back Light: 4 x CCFTs
Colors: 16.7M colors
MTBF: 50,000 hours

On Screen Control:

5 x OSD buttons

Video input:

15-pin D-sub VGA video input
Horizontal Synchronization: 64 - 80 KHz (Typ.)
Vertical Synchronization: 60 - 75 Hz (Typ.)

Input Device(Combo free connection):

104-key keyboard with touchpad (std) or Trackball (opt)

KVM feature:

System management with simultaneous multi-user access
Access server independly & simultaneously
8 characters password protection
Auto scan-mode and Hot-pluggable
Resolution: up to 1600x1200
SSL v2/ v3 encryption for secure transmission
On-board Membrane KVM switch to select server
Cascades up to 8 level/128servers on DB-15 KVM switch

Matrix KVM Switch Type:

16 DB-15 combo free KVM switch:
2 user consoles (1 x local/1 x remote)
2 user consoles (1 x local/2 x remote)
4 user consoles (1 x local/3 x remote)

Cascade port:

1 x DB-15 proprietary cascade port

User Console Type:

Local: 1 x 6' Combo free 4-in-1 Proprietary cable
Remote: over Cat6 cable with receiver

KVM port layout:

16 D-sub 15-pin proprietary KVM ports
1 x DB-15 porprietary KVM port
2 (std)/3/4 remote user port (RJ45 port)

KVM Cable:

16 6' 4-in-1 combo free proprietary KVM cable
Option for 10'/15'

Security Handle Lock:

Hard-plastic molded handle with 2 x positions lock

Drawer Design:

1U low profile clamp-type module design
Self-lock fixed-position slide rail
Adjustable rear mounting rails up to 34-inches depth.
Meets EIA310c & IEC-3 Specifications

Power supply:

100/240VAC Auto-sensing 48W 50/60Hz power adapter
Optional for 12/24/48VDC power input

ACNODES

14628 Central Blvd, Chino,
CA 91710
tel: 909.597.7588, fax: 909.597.1939

© Copyright 2011 Acnodes, Inc.
All rights reserved. Product description and product specifications
are subject to change without notice. For latest product information,
please visit Acnodes' web site at www.acnodes.com.



Color:
Black

Safety:
CE/FCC certificated

Gross Weight:
20lb

Dimension:
19"(W) x 25.6"(D) x 1.75"(H)

Environmental:
Temperature:
Operate 0°~ 50°C
Storage-5°~ 60°C
Shock: 10G acceleration (11ms duration)
Humidity: 0% ~ 80% non-condensing

» Diagram

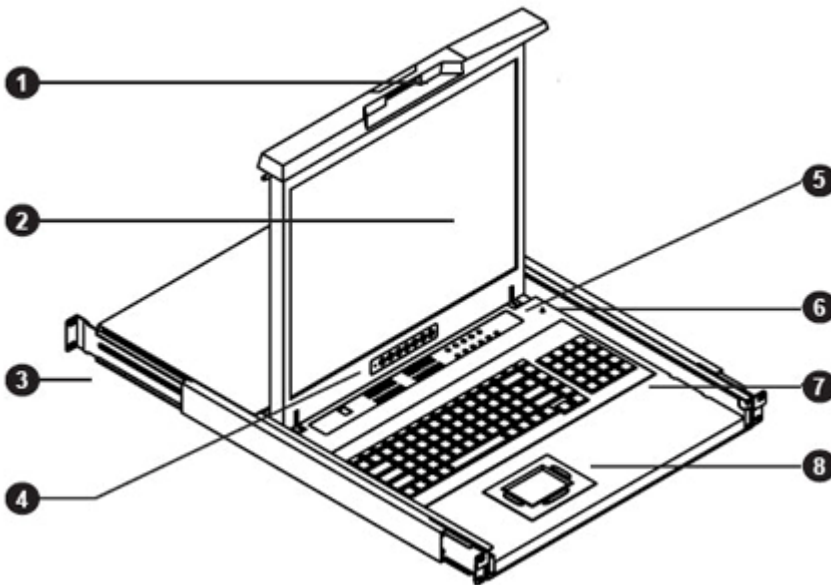

1. Carry handle to release the 2-pt lock
2. LCD interchangeable module kit
3. "One Man" installation Slides
4. LCD membrane
5. Membrane switch
6. Micro switch for screen auto power off
7. Keyboard interchangeable module kit
8. Mouse interchangeable module kit

» Ordering Guide

M1716: M console 17" LCD KVM keyboard drawer with integrated 16-port Matrix KVM switch, 2-user

» Optional Item

Mouse:
Touch-pad/Track-ball

Remote user Console:
2 (std) 3/4 (opt) remote user console port

Power supply:
12/24/48VDC power input

KVM cable:
Proprietary DB-15 4-in-1 KVM cable
6' 4-in-1 KVM cable KVM cable
10' 4-in-1 KVM cable KVM cable
15' 4-in-1 KVM cable KVM cable

Cascade cable:
3' matrix cascade cable

Receiver (for Remote user console):
Receiver with 1 x DB-15 4-in-1 KVM cable

ACNODES

14628 Central Blvd, Chino,
CA 91710
tel: 909.597.7588, fax: 909.597.1939

© Copyright 2011 Acnodes, Inc.
All rights reserved. Product description and product specifications
are subject to change without notice. For latest product information,
please visit Acnodes' web site at www.acnodes.com.