



## Mountings - Panel/Wall/Desktop/VESA

There are several mounting ways for the FPC 5084, Panel, Wall, Desktop and VESA mountings.

### 1. Panel Mounting

The FPC 5084 is designed for panel mount application. A set of standard mounting kit are bundled with the system package that you can use it to mount the FPC 5084.

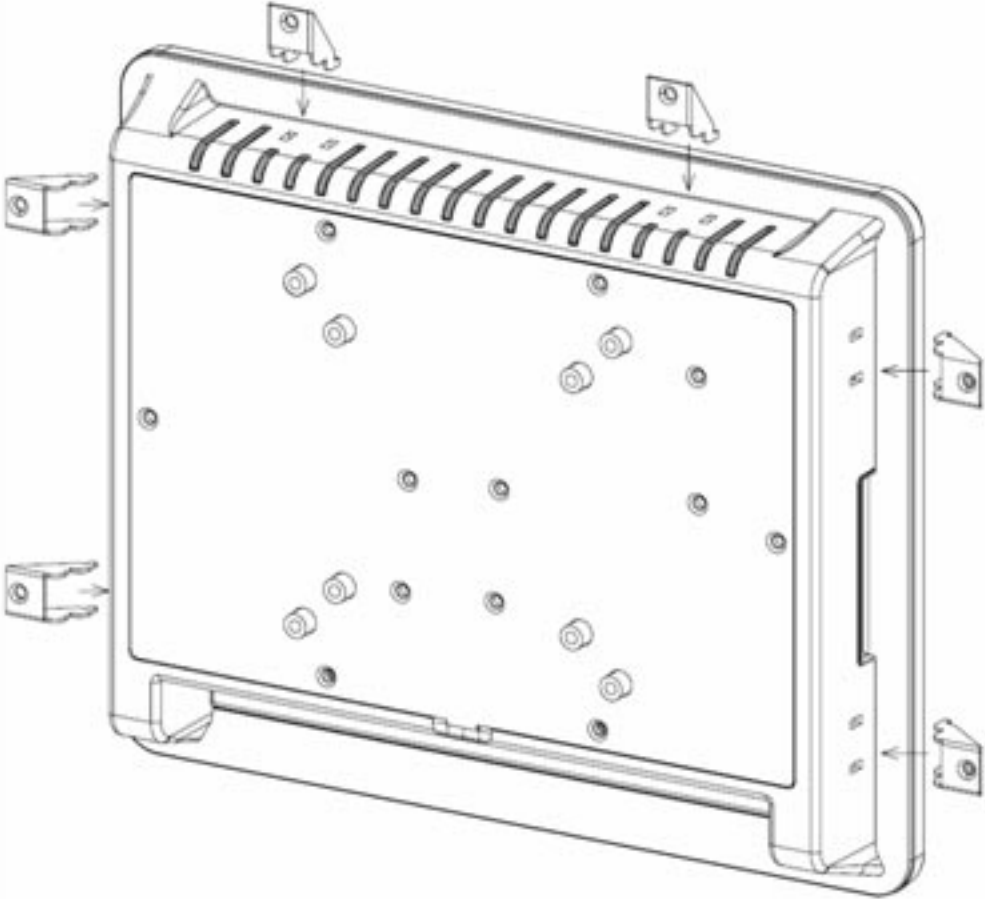



## 2. Wall-Mounting

The FPC 5084 is designed for Wall mounting application. Please refer to the following steps:  
Find out the screws as marked on the back side of chassis.





### 3. Desktop-Mounting

The FPC 5084 is designed for desktop mounting application. Please refer to the following steps:

**Step 1** Find out the screws as marked on the back side of chassis.





**Step 2** Assemble the desktop stand to the chassis, and fix the screws.





## 4. VESA-ARM Mounting

**Step 1** Find out the screws as marked on the back side of chassis.



**Step 2** Assemble the VESA-ARM to the back side of the chassis, and fix the screws.





**Step 3** VESA mounting Installation completed.

