

**FPC 8121**

**All-in-One**

**12.1" SVGA TFT Fanless Compact-Size**

**PANEL PC**

**User's Manual**

## **Disclaimers**

The information in this manual has been carefully checked and is believed to be accurate. ACNODES Co., Ltd. assumes no responsibility for any infringements of patents or other rights of third parties, which may result from its use.

ACNODES assumes no responsibility for any inaccuracies that may be contained in this document. ACNODES makes no commitment to update or to keep current the information contained in this manual.

ACNODES reserves the right to make improvements to this document and/or product at any time and without notice.

No part of this document may be reproduced, stored in a retrieval system, or transmitted, in any form or by any means, electronic, mechanical, photocopying, recording, or otherwise, without the prior written permission of ACNODES Co., Ltd.

**©Copyright 2006 by ACNODES Co., Ltd.**  
**All rights reserved.**  
**October 2006, Version A1**  
**Printed in Taiwan**

## Safety Approvals

- < CE Marking
- < FCC Class A

### **FCC Compliance**

This equipment has been tested and complies with the limits for a Class A digital device, pursuant to Part 15 of the FCC Rules. These limits are designed to provide reasonable protection against harmful interference in a residential installation. If not installed and used in accordance with proper instructions, this equipment might generate or radiate radio frequency energy and cause harmful interference to radio communications. However, there is no guarantee that interference will not occur in a particular installation. If this equipment does cause harmful interference to radio or television reception, which can be determined by turning the equipment off and on, the user is encouraged to try to correct the interference by one or more of the following measures:

1. Reorient or relocate the receiving antenna.
2. Increase the separation between the equipment and receiver.
3. Connect the equipment into an outlet on a circuit different from that to which the receiver is connected.
4. Consult the dealer or an experienced radio/TV technician for help.

Shielded interface cables must be used in order to comply with emission limits.

## Safety Precautions

Before getting started, read the following important cautions.

1. The FPC 8121 does not come equipped with an operating system. An operating system must be loaded first before installing any software into the computer.
2. Be sure to ground yourself to prevent static charge when installing the internal components. Use a grounding wrist strap and place all electronic components in any static-shielded devices. Most electronic components are sensitive to static electrical charge.
3. Disconnect the power cord from the FPC 8121 before making any installation. Be sure both the system and the external devices are turned OFF. Sudden surge of power could ruin sensitive components. Make sure the FPC 8121 is properly grounded.
4. The brightness of the flat panel display decreases with usage. However, hours of use vary depending on the application environment.
5. Turn OFF the system power before cleaning. Clean the system using a cloth only. Do not spray any liquid cleaner directly onto the screen. The FPC 8121 may come with or w/o a touchscreen. Although the touchscreen is chemical resistant, it is recommended that you spray the liquid cleaner on a cloth first before wiping the screen. In case your system comes without the touchscreen, you must follow the same procedure and not spray any cleaner on the flat panel directly.
6. Avoid using sharp objects to operate the touchscreen. Scratches on the touchscreen may cause malfunction or internal failure to the touchscreen.
7. The flat panel display is not susceptible to shock or vibration. When assembling the FPC 8121, make sure it is securely installed.

8. Do not open the system's back cover. If opening the cover for maintenance is a must, only a trained technician is allowed to do so. Integrated circuits on computer boards are sensitive to static electricity. To avoid damaging chips from electrostatic discharge, observe the following precautions:
  - 9 Before handling a board or integrated circuit, touch an unpainted portion of the system unit chassis for a few seconds. This will help to discharge any static electricity on your body.
  - 9 When handling boards and components, wear a wrist-grounding strap, available from most electronic component stores.

### **Trademarks Acknowledgments**

ACNODES is a trademark of ACNODES Co., Ltd.

IBM, PC/AT, PS/2, VGA are trademarks of International Business Machines Corporation.

Intel and Pentium are trademarks of Intel Corporation.

MS-DOS, Microsoft C and QuickBASIC are trademarks of Microsoft Corporation.

VIA is a trademark of VIA Technologies, Inc.

SST is a trademark of Silicon Storage Technology, Inc. UMC

is a trademark of United Microelectronics Corporation.

Other brand names and trademarks are the properties of their respective owners.

**This page does not contain any information.**

# Table of Contents

Disclaimers.....	ii
Safety Approvals.....	iii
Safety Precautions .....	iv
<b>Chapter 1</b> .....	<b>1</b>
<b>Introduction</b> .....	<b>1</b>
1.1 General Description .....	1
1.2 Specifications.....	2
1.2.1 Main CPU Board .....	2
1.2.2 I/O System.....	2
1.2.3 System Specification .....	9
1.3 Dimensions.....	10
1.4 I/O Outlets.....	11
1.5 Package List .....	13
<b>Chapter 2</b> .....	<b>14</b>
<b>Hardware Installation</b> .....	<b>14</b>
2.1 HDD Installation .....	14
2.2 CF card Installation.....	16
2.3 MiniPCI Wireless Card Installation .....	18
2.4 3 x Serial Ports .....	20
2.5 VGA .....	22
2.6 Ethernet.....	22
2.7 Mountings: Panel / Wall / Desktop / VESA.....	23
2.7.1 VESA-ARM/Wall-Mount .....	23
2.7.2 Desktop Kit Assembly .....	24
2.7.3 Panel-mount Kit Assembly .....	24
<b>Chapter 3</b> .....	<b>25</b>
<b>Driver Installation</b> .....	<b>25</b>
3.1 Touch Screen .....	25
3.1.1 Driver Installation- Windows XP.....	26

<b>3.2 Embedded O.S.....</b>	<b>29</b>
3.2.1 Windows XP Embedded.....	29
3.2.2 Windows CE.NET 5.0 .....	29

## Chapter 1

### Introduction

This chapter contains the general information and the detail specifications of the FPC 8121. Chapter 1 includes the following sections:

- |                               |                              |
|-------------------------------|------------------------------|
| „ <b>General Description</b>  | „ <b>I/O Outlets</b>         |
| „ <b>System Specification</b> | „ <b>Utilities Supported</b> |
| „ <b>Dimensions</b>           | „ <b>Package List</b>        |

### 1.1 General Description

The FPC 8121 is a fan-less and compact-size touch panel computer, and is equipped with a 12.1" TFT LCD display and low power consumption CPU. The FPC 8121 supports Windows® XP, Windows® CE.NET, Windows® XP embedded. The panel is also able to install a miniPCI module for extended wireless card and a CompactFlash™ card. The FPC 8121 is cost-effective choice for operator interface applications.

- „ FPC 8121: 12.1" SVGA TFT Fanless Touch panel w/extend temp.
- „ FPC 8121: 12.1" SVGA TFT Fanless Touch panel(Entry level)
- „ FPC 8121: 12.1" SVGA TFT Fanless Touch panel w/NEMA 4X front bezel

#### Reliable and Stable Design

The FPC 8121 adopts a fan-less cooling system and a CompactFlash™ card, which makes it especially suitable for vibration-heavy environments, best for the transportation, ship, and industrial machinery markets.

#### Embedded O.S. Supported

The FPC 8121 not only supports Windows® XP, but also supports embedded OS, such as Windows® CE.NET, and Windows® XP embedded. For storage device, the FPC 8121 supports

2.5" HDD or CompactFlash™ card.

### **Industrial-grade Product Design**

The FPC 8121 has an incredible design that can be used in different industrial harsh environments.

- z A fuse helps prevent over-voltage for power input.
- z Stainless front bezel (FPC 8121) meets IP65/NEMA4X and Aluminum front bezel(FPC 8121) meets the IP65/NEMA4 standard.
- z For connecting other devices, the FPC 8121 also features several interfaces: USB, Ethernet, and RS-232/422/485.

### **Wireless support- MiniPCI slot**

The FPC 8121 offers a MiniPCI slot that allow for wireless application requirements.

## **1.2 Specifications**

### **1.2.1 Main CPU Board**

- „ **CPU:** Intel® Celeron M ULV 1G/0k onboard
- „ **System Chipset:** Intel® 852GM +ICH\*4
- „ **BIOS:** AWARD BIOS, 4Mbit Flash ROM with RPL/PEX LAN boot ROM, SmartView and customer CMOS backup..
- „ **System Memory:** One 200-pin DDR DIMM socket.  
Maximum up to 1GB

### **1.2.2 I/O System**

- „ **Standard I/O:**
  - 3 x serial ports with power;  
2 x RS-232,  
1 x RS-232/422/485
  - 2 x USB Ports 2.0compliant

- ” **Ethernet:**
  - Realtek RTL 8100C PCI Bus 10/100M Base-T
  - RJ-45 interface equipped
- ” **Expansion Slot:**
  - MiniPCI wireless module

### 1.2.3 System Specification

- ” **12.1” TFT LCD**
- ” **Heat dispensing design**
- ” **One slot for MiniPCI**
- ” **Net weight:**
  - 5.4 Kg
- **Dimension (main body size):**
  - 332x 267 x 68.5mm
- **Operating temperature:** -15° to 50°C ; Relative humidity:40% (If the GOT series will be operated over 55°C for long time, please select the DRAM and HDD which supports wide-temperature)
- **Relative humidity:** 10% to 90% @ 40° C, on-condensing
- ” **Vibration (operating):**
  - 5 to 500 Hz, 1.0 G random ( install HDD )
  - 5 to 500 Hz, 2.0 G random ( install CompactFlash card )

### 1.3 Dimensions

The following diagrams show the dimensions and outlines of FPC 8121.

” FPC 8121 dimension

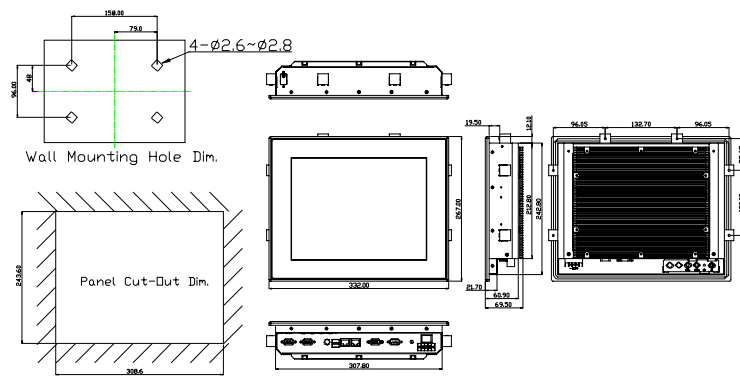

” FPC 8121 dimension

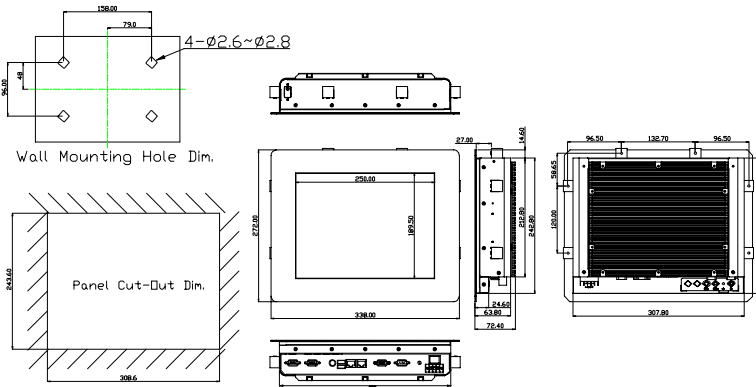

## 1.4 I/O Outlets

The following figure shows the I/O locations of the FPC 8121. Most of the I/O connectors are located on the back panel of the FPC 8121.

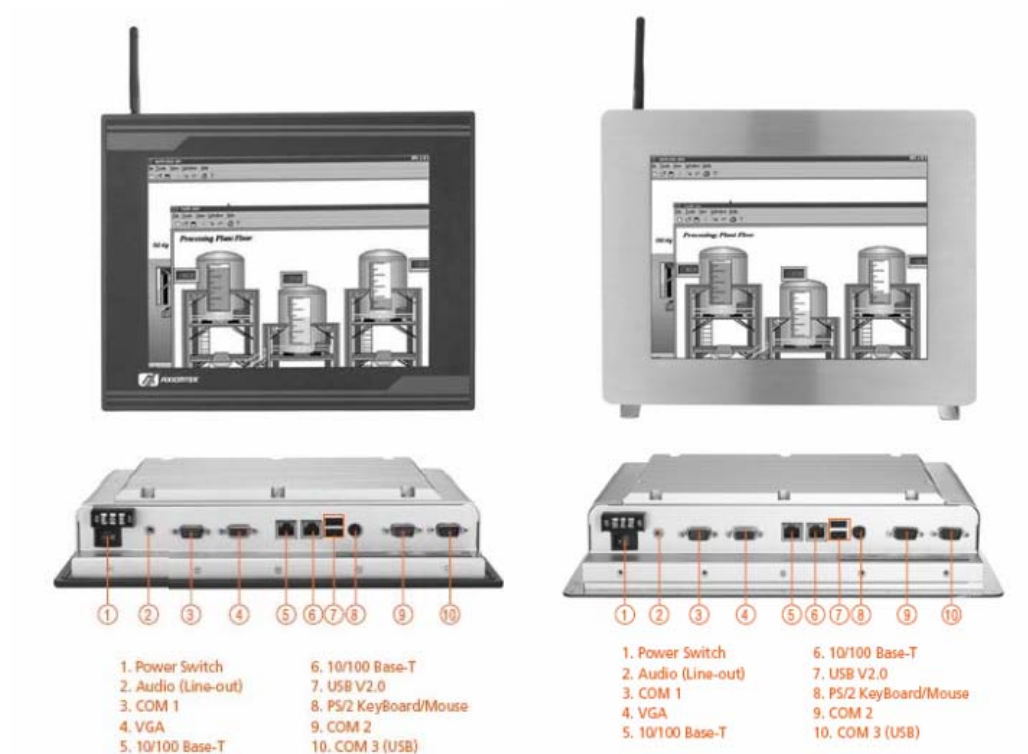

- |                           |                              |
|---------------------------|------------------------------|
| <b>1:</b> Power Switch    | <b>6:</b> 10/100 Base-T      |
| <b>2:</b> Audio(Line out) | <b>7:</b> USB v2.0           |
| <b>3:</b> COM1            | <b>8:</b> PS2 keyboard/mouse |
| <b>4:</b> VGA             | <b>9:</b> COM2               |
| <b>5:</b> 10/100 Base-T   | <b>10:</b> COM3 (USB)        |

## **1.5 Package List**

When you receive the FPC 8121 there are following items in the package. If you can not find it, please contact ACNODES distributors.

1. FPC 8121 x 1
2. CD driver x1
3. Panel mount kit x 6
4. Anti-vibration HDD rubber x5
5. Y cable for PS2 keyboard/mouse
6. Antenna x1
7. Desktop kit x 2(optional)
8. VESA ARM/Wall-mount kit x 1(optional)
9. Jumper

## Chapter 2

### Hardware Installation

The FPC 8121 provides lots of flexible ways for you to select different configuration such as HDD,(recommend adopt wide temperature HDD in harsh environment) CF card and more. The chapter will show you how to install the hardware. It includes:

#### 2.1 HDD Installation

The FPC 8121 offers a convenient drive bay module for users to install HDD. The FPC 8121 offers one 2.5" HDD drive for users to install. Please follow the steps:

1. Take out HDD bracket kit, 4 anti-vibration screws, 4 anti-vibration rubbers and 4 bracket screws from the accessory package.



2. Screw 4 anti-vibration screws and fix HDD on the bracket kit.



3. Fix the HDD kit to system by 4 screws.

## **2.2 CF card Installation**

The FPC 8121 offers a solution for users to install CF card. When installing the CF card, refer to the following instructions and illustration:

1. Take apart FPC 8121 and find embedded system board from system and turn it to back side.

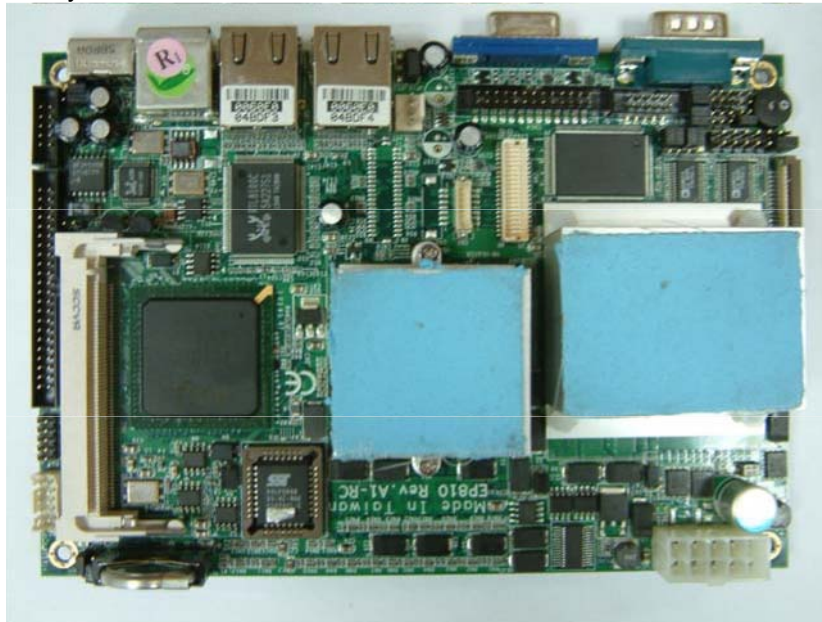

2. Install user's CF card.

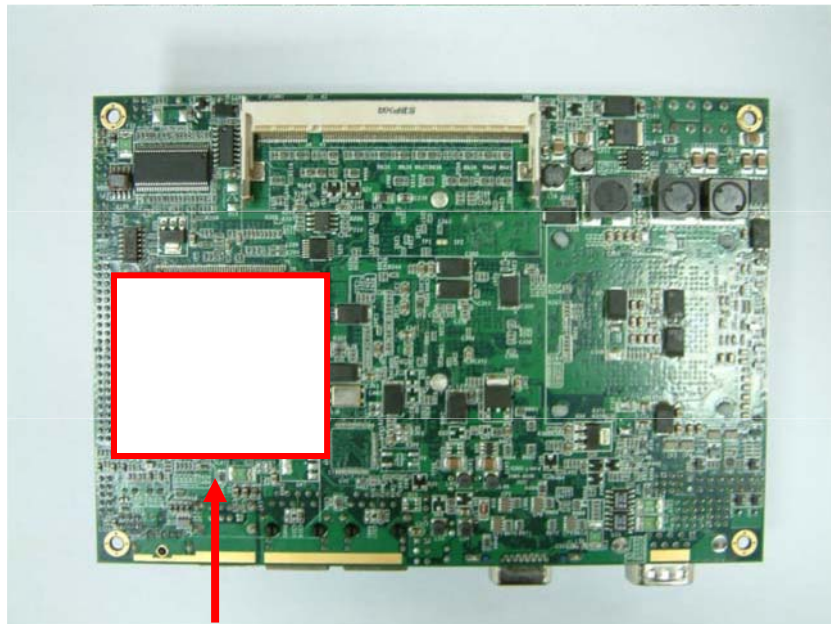

### **2.3 MiniPCI Wireless Card Installation**

The FPC 8121 provides one Mini PCI slot for wireless module.(Default Wireless module:AC92203 ) When installing the wireless card, refer to the following instructions and illustration:

1. Find EMBEDDED board(EP810).

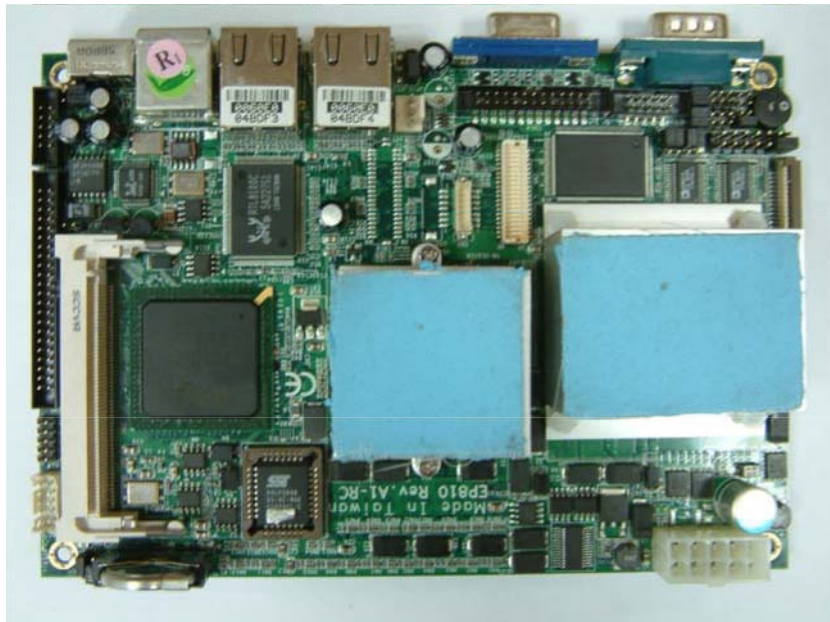

2. Install user's Wireless card.

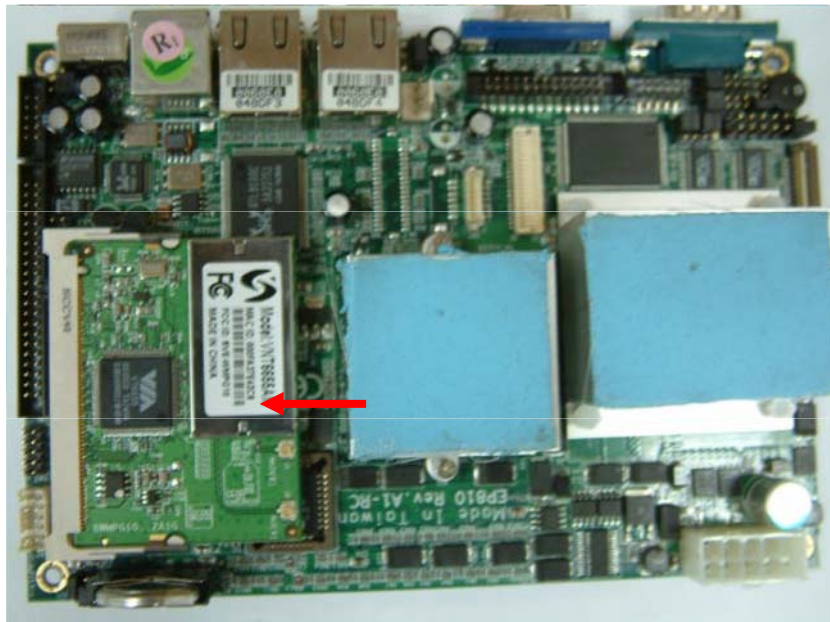

3. Assembly embedded board back into FPC 8121.

## 2.4 3 x Serial Ports

### COM Port Connector: COM1

The connector, COM 1, is a DB-9 connector, and the following table shows the pin assignments of this connector.

Pin	Signal Name
1	DCD, Data carrier detect
2	RXD, Receive data
3	TXD, Transmit data
4	DTR, Data terminal ready
5	GND, ground
6	DSR, Data set ready
7	RTS, Request to send
8	CTS, Clear to send
9	RI, Ring indicator

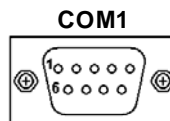

### COM Port Connectors:

The RS-232 pin assignments are listed on the following table.

Pin	Description	Pin	Description
1	Data Carrier Detect (DCD)	2	Data Set Ready (DSR)
3	Receive Data (RXD)	4	Request to Send
5	Transmit Data (TXD)	6	Clear to Send (CTS)
7	Data Terminal Ready (DTR)	8	Ring Indicator (RI)
9	Ground (GND)	10	NC

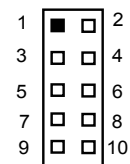

The RS-422/485 pin assignments for COM2 are listed below.

Pin #	Signal Name	
	R2-422	RS-485
1	TX-	DATA-
2	No connector	No connector
3	TX+	DATA+
4	No connector	No connector
5	RX+	No connector
6	No connector	No connector
7	RX-	No connector
8	No connector	No connector
9	GND	GND
10	No connector	No connector

## 2.5 VGA

The FPC 8121 has an analog RGB interface connector. It is able to connect to an expansion CRT monitor, and the system can display on both the flat panel and the CRT simultaneously.

## 2.6 Ethernet

### Ethernet RJ-45 Connector: LAN1

The **FPC 8121** is equipped with a high performance Plug and Play Ethernet interface which is fully compliant with the IEEE 802.3 standard, and consisting of a RJ-45 connector LAN

#### 3.4.15.1 Pin Assignment

#### LAN1: RJ-45 Connector Pin Assignment

Pin	Signal
1	Tx+ (Data transmission positive)
2	Tx- (Data transmission negative)
3	Rx+(Data reception positive)
4	RJ45 termination
5	RJ45 termination
6	Rx- (Data reception negative)
7	RJ45 termination
8	RJ45 termination

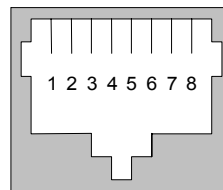

RJ-45

## **2.7 Mountings: Panel / Wall / Desktop / VESA**

There are 4 application options for the FPC 8121, Panel/Wall/Desktop/VESA mountings.

### **2.7.1 VESA-ARM/Wall-Mount**

The FPC 8121 provides two ways for VESA mount: 75x75 mm Screw four screws to fix the kit (optional) in the back chassis.



### **2.7.2 Desktop Kit Assembly**

The FPC 8121 is designed for desktop application. The standard set of desktop kit is included in the system packaging. Screw 4 screws to fix the kit (Optional) in the side chassis.



### **2.7.3 Panel-mount Kit Assembly**

The FPC 8121 is designed for panel mount application. To mount the FPC 8121, the standard set of mounting kit (included in the system packaging) is needed.



## Chapter 3

### Driver Installation

FPC 8121 could support with Windows XP. To facilitate installation system driver, you should read the instructions in this chapter carefully before you attempt installation.

1. Insert Driver CD and select the “\FPC 8121&3128T driver\Driver”.



2. Select all files and follow the install procedure.

### 3.1 Touch Screen

#### Specification(FPC 8121)

Touch Screen:	For 5-wire analog resistive type (ELO)
Touch Screen Controller:	Penmount 51A5E
Communications:	USB interface
Contact bounce:	< 15ms
Board Size:	271.2 x 205.7 mm
Operating Temperature:	-10°C ~ 60°C Humidity less than 85% RH

**Specification(FPC 8121)**

Touch Screen:	For 5-wire analog resistive type
Touch Screen Controller:	Penmount 51A5E
Communications:	USB interface
Contact bounce:	< 15ms
Board Size:	271.2 x 205.7 mm
Operating Temperature:	-10°C ~ 60°C Humidity less than 85% RH

**3.1.1 Driver Installation- Windows XP**

The touch screen of FPC 8121 provides a driver for use with Windows XP. To facilitate installation of the touch screen driver, you should read the instructions in this chapter carefully before you attempt installation.

1. Insert Driver CD and select the “driver\  
Driver\Touch\Windows XP Driver V4.0(WHQL)\Setup.exe”



2. Follow the install procedure and press OK.
3. Click Start menu and select “PenMount Utilities”. You can see PenMount Control Panel

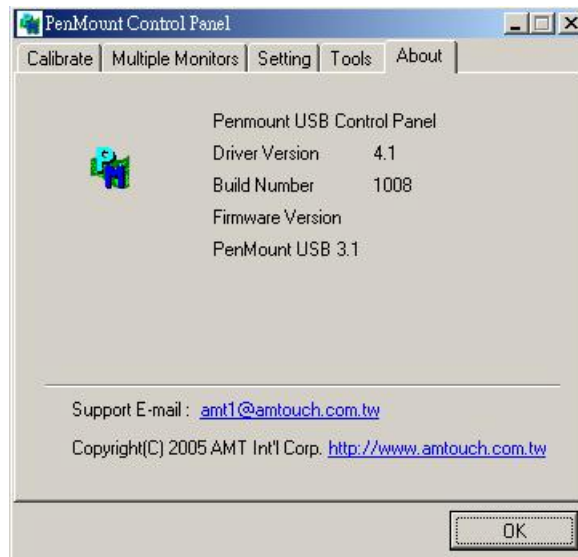

4. Select the "Standard Calibrate" tab

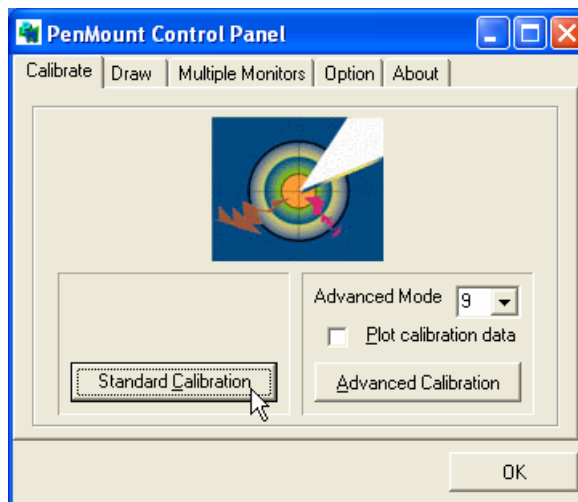

5. Calibration:

To adjust the display with touch panel, click "Calibration" and follow the calibrate point to do calibration; there are five points on screen for calibration.

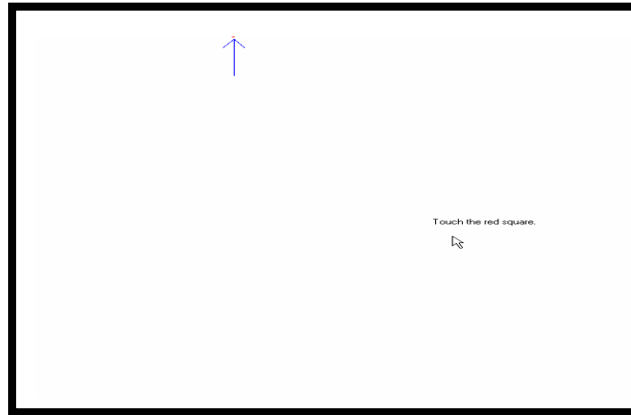

6. Press OK.

## 3.2 Embedded O.S.

### 3.2.1 Windows XP Embedded

Supported onboard devices are as follows:

- „ Onboard Multi I/O
  - Floppy drive
  - 16C550 UARTs compatible serial port
- „ Onboard IDE
  - IDE HDD
- „ USB
- „ PS2 Keyboard and mouse
- „ CRT/LCD display
- „ 10/100 base-T Ethernet
- „ Compact flash
- „ Onboard audio
- „ Audio
- „ Touch Screen

#### PenMount Touch screen

FPC 8121 has Penmount touch screen on USB. Before

you can use and calibrate it, you should :

1. Set up Penmount touch device driver by executing c:\Program Files\Penmount USB\Install.exe. When installation finished, an icon “PM” appears on Taskbar .
2. Calibrate Penmount touch by clicking on “PM” icon and doing calibration
3. Restart computer.

### 3.2.2 Windows CE.NET 5.0

Supported onboard devices are as follows:

- „ Onboard Multi I/O
  - Floppy drive
  - 16C550 UARTs compatible serial port
- „ Onboard IDE

- IDE HDD
- ” USB
- ” PS2 Keyboard and mouse
- ” CRT/LCD display
- ” 10/100 base-T Ethernet
- ” Compact flash
- ” Onboard audio
- ” Audio
- ” Touch Screen

### **Calibration Touch Screen**

In this image we add PenMount Touch drivers and utilities. It is customized for 800 x 600.

#### Calibration:

1. Click “Calibration” on desktop to calibrate touch screen.
2. In the start\programs menu, select “save registry”, thus Calibration data will be saved and effective in next boot.